



ENDÜSTRİYEL ELEKTRONİK

İkitelli Org. San. Böl. Trike Center 7-in Blok

No: 301 - 303 İkitelli - İstanbul

Tel : 0212 671 59 12 - 671 59 28 - 617 59 42 Fax: 0212 671 50 43

www.gestr.com - e-mail : info@gestr.com

STKN01 MANUAL INSTRUCTIONS (GES-T-13) ISO9001:2000

STKN01 ELECTRICAL FITTING

THE LENGTH OF CABLES SHALL BE MAXIMUM 400 CM

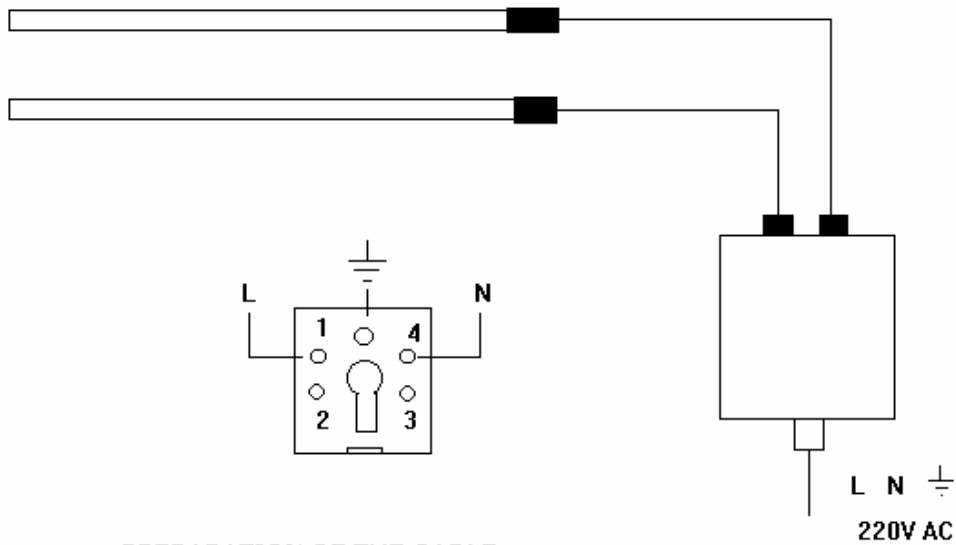

PREPARATION OF THE CABLE

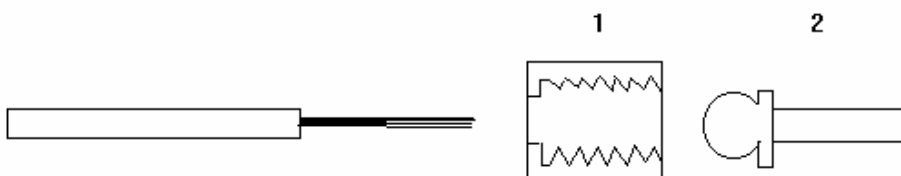

- OPEN THE CABLE 5 mm MORE THAN NO:2 ITEM'S LENGTH

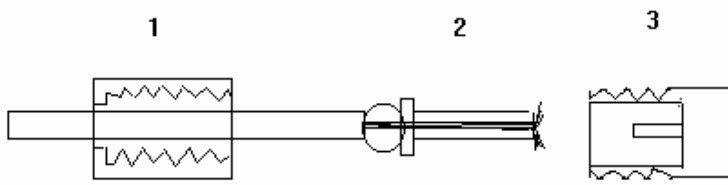

- FIRSTLY, TAKE NO:1 ITEM ABOVE THE CABLE AND THAN PASS ON NO:2 ITEM TO OPENED COPPER WIRE AND TWIST THE REMAINING 3-4 MM WIRE TO BOTH SIDES.APPLY THESE SETTINGS FOR BOTH SIDES OF THE CABLE.

-TAKE THE SOCKET NO:2 PREPARED IN THE CABLE.THAN FIT INTO NO:3 PART OF BOTH THE ROT AND THE MAIN INSTRUMENT. CLOSE THEM TOGETHER WITH NO:1 ITEMS

STKN01 SWINGING BAR FITTING GRAPH

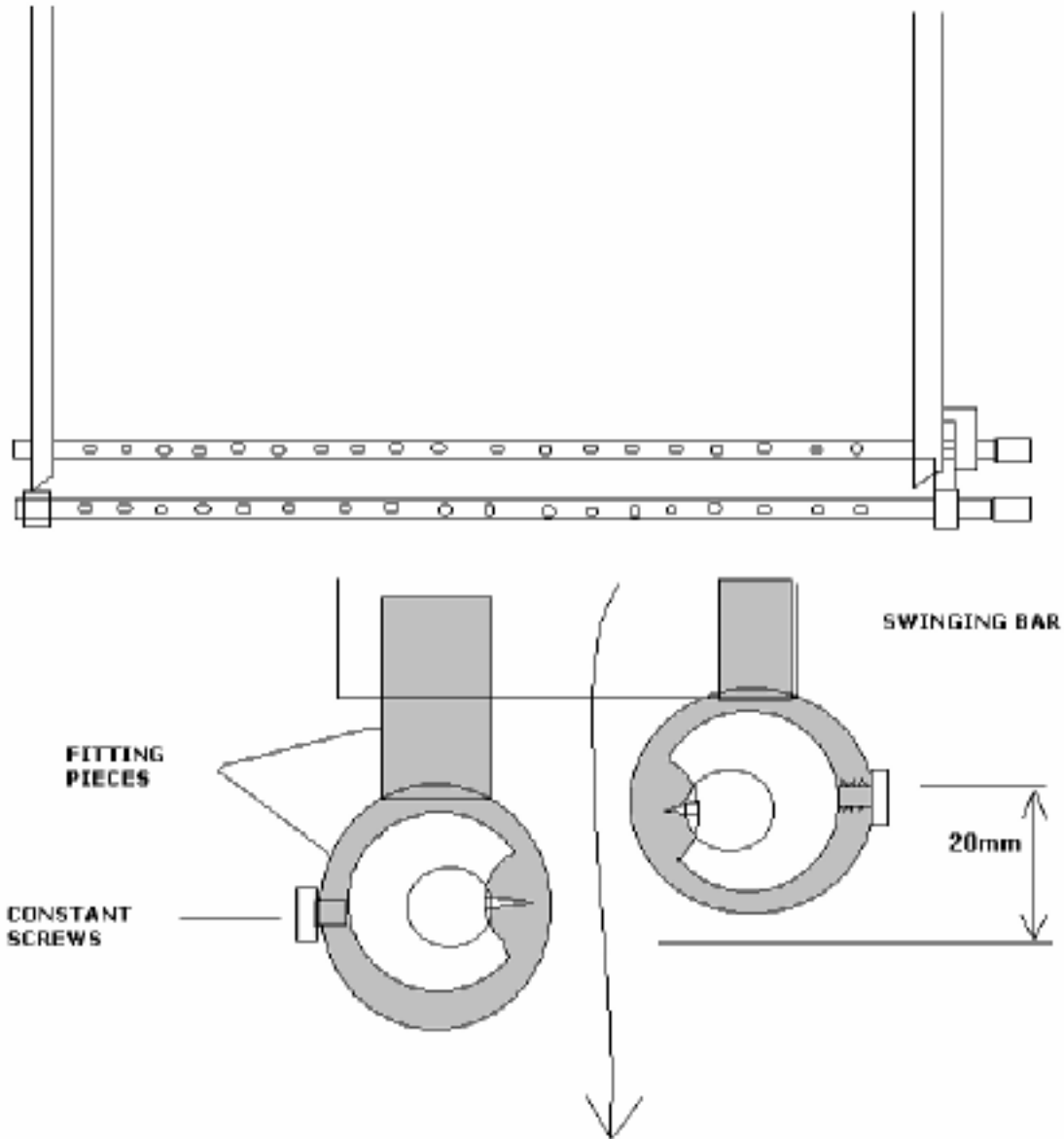

- THE NEEDLES IN BOTH ROT ARE GOING TO BE FACING FABRIC SURFACE
- THE PARTS ARE GOING TO BE CONNECTED TO SWINGING BARS DIRECTLY VIA CONNECTION ITEMS
- THERE SHALL BE 2 CM DISTANCE BETWEEN THE ROTS SETTLED UPWARDS AND DOWNWARDS
- THERE SHALL BE 3 - 4 CM DISTANCE BETWEEN THE ROTS
- THE ROTS SHALL BE FIT AT THE END OF SWINGING BAR
- THE FABRIC SHALL REACH BOTH OF THE ROTS WHILE SWINGING PERIOD